

# TECNOVAP

L'ARTE DEL VAPORE

User instruction

- **STEAM POWER**
- **STEAM POWER PLUS**
- **STEAM TURBO**



This manual is available in digital format, by submitting a specific request to the following address: [info@tecnovap.com](mailto:info@tecnovap.com)

visit our website

[WWW.TECNOVAP.IT](http://WWW.TECNOVAP.IT)









## Interpretation of the symbols placed on the unit



**BEFORE USING THE STEAM GENERATOR, READ AND FOLLOW THIS INSTRUCTION MANUAL.**

**IT IS RECOMMENDED TO KEEP THIS INSTRUCTION MANUAL TO CONSULT IT LATER OR TO GIVE IT TO THE FOLLOWING OWNERS.**

**PLEASE READ THE SAFETY INSTRUCTIONS ON THIS HANDBOOK BEFORE PROCEEDING WITH THE FIRST USE. EVENTUAL DAMAGES DUE TO THE CARRIAGE MUST BE COMMUNICATED AS SOON AS POSSIBLE TO YOUR OWN RETAILER.**

	<p><b>ATTENTION!!</b> <b>STEAM.... BURNING DANGER</b></p>
	<p><b>ATTENTION!!</b></p>
	<p><b>READ THE OPERATING MANUAL</b></p>
	<p><b>OPERATING MANUAL;</b> <b>OPERATING INSTRUCTIONS</b></p>
	<p><b>ATTENTION!!</b> <b>DO NOT DIRECT THE JET TOWARD PERSONS, ANIMALS,</b> <b>ELECTRIC SOCKETS AND EQUIPMENTS.</b></p>

## Interpretation of the obligation symbols placed on the unit

	<p><b>BURNING DANGER!!</b> IT IS COMPULSORY TO USE PROTECTIVE GLOVES.</p>
	<p><b>EQUIPMENT WITH SOUND PRESSURE LEVEL &gt; 85db</b> IT IS COMPULSORY TO USE EARS PROTECTIVE SHROUDS.</p>

## Environment protection

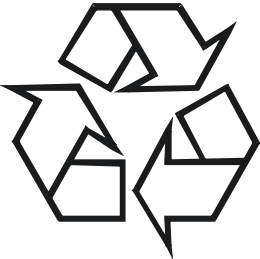
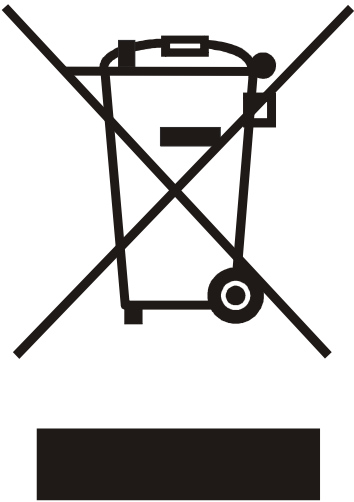
	<p>ALL THE PACKINGS ARE RECYCLABLE, PACKINGS DO NOT HAVE TO BE THROWN IN THE DOMESTIC WASTE BUT THEY HAVE TO BE DELIVERED TO THE CENTERS SPECIALIZED FOR THE DISPOSING OF THE WASTE.</p>
	<p>ALL DEVICES NOT USED ANYMORE CONTAIN PRECIOUS RECYCLABLE MATERIALS THAT SHOULD BE DELIVERED TO THE CENTERS SUITABLE FOR THE DISPOSING OF THE WASTE. ELECTRIC AND ELECTRONIC EQUIPMENT, BATTERIES, OIL AND SIMILAR SUBSTANCES MUST BE RECYCLED IN THE PROPER RECYCLING CENTERS AND MUST NOT BE LEFT IN THE ENVIRONMENT.</p>
<p>THE USER MIGHT RETURN THE UNIT FOR DISPOSAL ALSO TO THE RETAILER WHEN PURCHASING A NEW EQUIVALENT DEVICE ON A ONE TO ONE RATIO.</p>	

## SUMMARY

1. RISK PREVENTION
3. CONNECTION TO THE WATER NET
4. PREFACE
5. TECHNICAL CHARACTERISTICS
6. NOMENCLATURE
7. TECHNICAL DRAWINGS
8. OPERATING INSTRUCTIONS
9. MAINTENANCE
10. BEFORE REFERRING TO THE TECHNICAL SERVICE
11. DECLARATION OF CONFORMITY

### 1. RISK PREVENTION

#### 1.1 SAFETY COMPONENTS

**SAFETY VALVE** This machine is equipped with two safety valves, able to ensure the safety of the machine itself in case other primary control devices are inefficient (due to a failure). Due to the extreme importance of these components and as not to compromise the safety of the machine, it is recommended to provide to check them and to substitute them through an authorized service center every 2 years starting from the purchasing date.

**PRESSURE SWITCH** This machine is equipped with a pressure switch able to check and to maintain the pressure under certain preset limits (ref. "rated pressure" on the technical label underneath the machine). In case there would be a steam leakage on the lower side of the machine, it means that the functioning of this device has been compromised and the safety valve has been involved as to limit the boiler's internal pressure. **It is recommended not to use the machine, immediately unplug the machine from the power feeding and call the service center.**

**THERMOSTATS.** The unit is equipped with thermostats able to control the overtemperature. In case the main control system becomes inefficient, they would intervene permanently by deactivating the boiler heating. If this occurs, disconnect the power plug and contact a service center.

▪ **MUD DRAIN FROM THE BOILER** The unit automatically indicates the necessity to proceed with the mud drain; the notice C A L C will be displayed alternatively to the current visualization on the panel.

## 1.2 MEASURES TO BE FOLLOWED

- It is recommended not to open or remove any machine part for any reason; in case the unit should present an abnormal functioning or a failure, disconnect the power plug and contact an authorized service center or the dealer where the product has been purchased.
- The electric supply connection shall be made by a qualified electrician and comply with IEC 60364-1.
- If the power cable is damaged, it has to be replaced by the manufacturer or by an authorized technical service or by a qualified person in order to prevent any risk.
- It is recommended that the electric supply to this machine should include either a residual current device that will interrupt the supply if the leakage current to earth exceeds 30ma for 30ms or a device which will prove the earth circuit.
- Risk of explosion. Do not spray flammable liquids.
- The employer shall perform a risk assessment in order to specify the necessary protective measures regarding aerosols, depending on the surface to be cleaned and its environment. Respiratory masks of class FFP2, an equivalent or higher are suitable for the protection against hydrous aerosols.
- Do not use the appliance within the range of persons.
- The high pressure jets can be dangerous if not used properly. The jet does not have to be directed against persons, electrical devices under tension or the unit itself.
- Do not direct the jet against yourself or others in order to clean clothes or footwear.
- Disconnect the power supply by unplugging the plug from the electric socket before proceeding with the maintenance effected by the user.
- This appliance is not intended for use by people (children included) with impaired physical, mental or sensory capacities or with insufficient experience and/or expertise, unless they are being supervised or instructed on the use of the appliance by a person responsible for their safety.
- Monitor the children so they cannot play with the machine.
- To ensure the machine's safety, use only original spare parts from the manufacturer or spare parts approved by the manufacturer.
- Pressure hoses, fitting and couplings are important for the safety of the machine. Use only hoses, fitting and couplings recommended by the manufacturer.
- Do not use the machine if the power cord or other important parts of the machine are damaged, i.e. safety devices, pressure hoses and trigger gun.
- If an extension cord is used, the plug and socket must be of a watertight construction.
- Inadequate extension cords can be dangerous.
- **The recoil forces of the “high pressure” function are 31.38N, therefore when activating the trigger gun, a sudden twisting moment manifests; firmly hold the lance and the gun before activating the command lever. Failure to comply with what indicated may cause serious injury.**
- The detergent injection on this appliance must not be used continuously, use only intermittently, 20 seconds ON 20 seconds OFF. Do not run the detergent function continuously for more than 2 minutes. This appliance has been designed for use with cleaning agent supplied or recommended by

the manufacturer. The use of other cleaning agents or chemicals may adversely affect the safety of the user and of the appliance itself.

When using detergents (non-foaming for extraction machines), follow the specific instructions given on the original packaging: usually this is 1 litre of detergent for every 10 litres of water (detergent percentage approximately 10%), taking care to pour the detergent in first in order to obtain a better mixture.

**Take great care of the detergent used, as some that are available on the market, when heated to over 100°C, thus to a gaseous state, may produce highly toxic vapours. Check the technical data sheet of the product or consult your supplier.**

In the event of accidental contact with the detergent used, strictly follow the instructions given on the package and the relative safety data sheet.

- Wear gloves and ears protective shrouds when using the appliance.

## 2. CONNECTION TO THE WATER NET

The connection to the water net shall be made by qualified personnel. It is recommended to use a new set of food grade fittings and food grade hoses; it is not possible to use again the same set (fittings, tubes, gaskets, reductions etc.) for a new connection.

Being a movable device, the connection hose to the water net is not supplied due to the unknown distance from the water connection point.

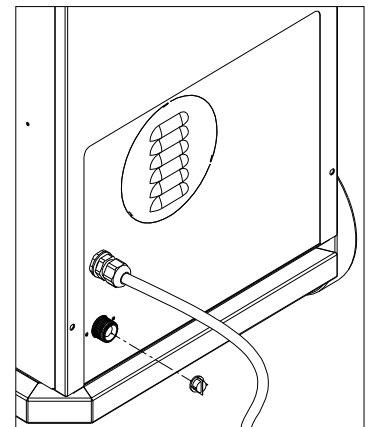

### 3. PREFACE

Dear Client,

We would like to congratulate you on your choice.

With the goal of improving and continually updating production by always offering innovative products, TECNOVAP has studied, designed and created the **STEAM POWER**, a combined machine for cleaning which brings together the power of steam, the efficiency of high pressure water and the force of vacuuming (optional).

This product is equipped with a dependable stainless steel boiler with automatic refilling system which allows it to produce a powerful and continuous supply of steam (24/24 hours).

The **STEAM POWER** model is also equipped with a separate detergent tank which enables the injection of a detergent at 90-160°C and with an overheated water injection system.

With the power of steam, meaning ecological cleaning power, TECNOVAP has combined a pump able to supply water up to the pressure of 150 bar, and a powerful vacuum (optional) able to pick up solids and liquids.

**STEAM POWER** is the ideal solution when it comes to cleaning and disinfecting.



## 4. TECHNICAL FEATURES

FACTORY: TECNOVAP SRL VIA DEI SASSI 1A 37026 PESCANTINA VERONA ITALY

Model		10,8	14,4	18,0	21,6	28,8	36,0
Code		6H06000	6H05000	6H04000	6H03000 6H0300M	6H02000	6H01000 6H0100M
Rated Voltage	V	400/230					
Current type	Hz	50/60 3~					
Rated Power Boiler	kW	10,8	14,4	18,0	21,6	28,8	36,0
Rated Power Vacuum	kW	3					
Power Pump Module 13L	kW	4					
Max Rated Power 13L/m	kW	17.8	18.4	21	21.6	35.8	39.4
Rated Steam Pressure	kPa bar	100 -> 1000 1 -> 10					
Rated Water Pressure	kPa bar	15000 150					
Permissible Steam Pressure	kPa bar	1200 12					
Max. Steam Rated Flow	kg/h	17,5	23,0	29,1	35,0	46,5	58,0
Max. Water Rated Flow	l/m	13					
Max temperature	°C	183					
Max. inlet water pressure	KPa Bar	600 6					
Kickback forces (13l/m)	N	31,38					
Vibration hand-arm	m/s <sup>2</sup>	< 2,5					
Sound pressure level L <sub>Pa</sub>	Db	98,7					
Sound power level L <sub>wa</sub>	dB	111,4					
Mass	Kg	180					

## MODELS WITH HIGH PRESSURE PUMP ONLY

Model		10,8	14,4	18,0	21,6	28,8	36,0
Code		6H06P00	6H05P00	6H04P00	6H03P00 6H03P0M	6H02P00	6H01P00 6H01P0M
Rated Voltage	V	400/230					
Current type	Hz	50/60 3~					
Rated Power Boiler	kW	10,8	14,4	18,0	21,6	28,8	36,0
Rated Power Vacuum	kW	/					
Power Pump Module 13L	kW	4					
Max Rated Power 13L/m	kW	14.8	18.4	18,4	21.6	32.8	40.0
Rated Steam Pressure	kPa bar	100 -> 1000 1 -> 10					
Rated Water Pressure	kPa bar	15000 150					
Permissible Steam Pressure	kPa bar	1200 12					
Max. Steam Rated Flow	kg/h	17,5	23,0	29,1	35,0	46,5	58,0
Max. Water Rated Flow	l/m	13					
Max temperature	°C	183					
Max. inlet water pressure	KPa Bar	600 6					
Kickback forces (13l/m)	N	31,38					
Vibration hand-arm	m/s <sup>2</sup>	< 2,5					
Sound pressure level L <sub>Pa</sub>	Db	98,7					
Sound power level L <sub>wa</sub>	dB	111,4					
Mass	Kg	165					

## MODELS WITH VACUUM CLEANER ONLY

Model		10,8	14,4	18,0	21,6	28,8	36,0
Code		6H06T00	6H05T00	6H04T00	6H03T00 6H03T0M	6H02T00	6H01T00 6H01T0M
Rated Voltage	V	400/230					
Current type	Hz	50/60 3~					
Rated Power Boiler	kW	10,8	14,4	18,0	21,6	28,8	36,0
Rated Power Vacuum	kW	3					
Power Pump Module 13L	kW	/					
Max Rated Power 13L/m	kW	10.8	17.4	21	21.6	31.8	39.0
Rated Steam Pressure	kPa bar	100 -> 1000 1 -> 10					
Rated Water Pressure	kPa bar	15000 150					
Permissible Steam Pressure	kPa bar	1200 12					
Max. Steam Rated Flow	kg/h	17,5	23,0	29,1	35,0	46,5	58,0
Max. Water Rated Flow	l/m	13					
Max temperature	°C	183					
Max. inlet water pressure	KPa Bar	600 6					
Kickback forces (13l/m)	N	31,38					
Vibration hand-arm	m/s <sup>2</sup>	< 2,5					
Sound pressure level LPa	Db	98,7					
Sound power level Lwa	dB	111,4					
Mass	Kg	170					

## 5. NOMENCLATURE

- 01) Power cord with plug
- 02) Water inlet for direct water feed
- 03) Direct water feed filter
- 04) General power switch
- 05) Manoeuvring handle
- 06) Steam hose connection socket
- 07) High pressure hose M22 connection (optional)
- 08) Pump pressure regulator (optional)
- 09) High pressure manometer (optional)
- 10) High pressure pump (optional)
- 11) Inspection window for H.P. pump oil (optional)
- 12) Control panel
- 13) Water tank cap
- 14) Water tank drainage cap
- 14A) Water tank filter
- 14B) Water tank filter cap
- 15) Detergent tank cap
- 16) Detergent tank drainage cap
- 16A) Detergent tank filter
- 16B) Detergent tank filter cap
- 17) Boiler drainage cap
- 18) Boiler drainage key
- 19) Female suction hose inlet (optional)
- 20) Suction hose inlet safety clamp (optional)
- 21) Suction unit support (optional)
- 22) Suction unit bin (optional)
- 23) Suction unit motor fastening catches (optional)
- 24) Female suction hose inlet (optional)
- 25) Suction hose inlet safety clamp (optional)
- 26) Suction unit motor head (optional)
- 27) Suction unit bin - turbine coupling hose (optional)
- 28) Turbine (optional)
- Radames hose**
- 29) Radames hose handle
- 30) Steam/hot water/detergent delivery button
- 30A) Delivery button locking lever
- 31) Steam selector (min-med-max)
- 31A) "Minimum steam" indicator light
- 31B) "Medium steam" indicator light
- 31C) "Maximum steam" indicator light
- 32) Suction unit button
- 32A) "Suction" indicator light
- 33) Overheated water delivery button
- 33A) "Overheated water" indicator light
- 34) Detergent delivery button (intermittent)
- 34A) "Detergent" indicator light
- 35) "Steam ready" light
- 36) Steam hose connector jack
- 37) Male suction hose
- 38) Steam/suction extension tubes
- 39) Locking lever
- 40) Fastening knob
- 41) Steam/suction turbo lance (optional)
- 42) Brass brush (Ø 28mm) (optional)
- 43) Stainless steel brush (Ø 28mm) (optional)
- 44) Stainless steel brush (Ø 60mm) (optional)
- 45) Stainless steel scourer (optional)
- 46) Inserts holder brush
- 47) Inserts locking lever
- 48) Rubber/bristle Insert (L. 375mm)
- 48A) Rubber/rubber insert (L.375mm)
- 49) Industrial steam/suction brush L.530 (optional)
- 50) Stainless steel accessory for upholstery (optional)
- Geyser 1 hose**
- 51) Detergent delivery button/switch
- 52) Overheated water delivery button/switch
- 53) Steam delivery button
- 54) Steam hose connector jack
- 55) Steam lance 100 / 400 / 800 / 1200 mm
- Geyser 2 hose**
- 60) Detergent delivery button/switch
- 61) Overheated water delivery button/switch
- 62) Steam delivery button
- 63) High pressure water delivery lever
- 64) High pressure hose connector jack
- 65) Steam hose connector jack
- 66) Steam/high pressure water lance 800 /1200 mm
- Bacchus accessories (optional)**
- 70) Steam hose connector jack
- 71) Hose/system quick-fit connector
- 72) Steam connector Garolla fitting
- 73) System overpressure safety valve
- 74) Garolla fitting
- 75) Safety pressure switch (optional)
- Suction hose (optional)**
- 76) Suction hose for Geyser 1 and 2 hoses
- 77) Flat lance
- 78) Liquids/dust floor tool
- Accessories (optional)**
- 80) Round nozzle
- 81) Window cleaner with diffuser 250 / 350 / 450 mm
- 82) Steam brush with bristles 250 / 350 / 450 mm
- 83) Stainless steel floor scraper
- 84) 4 cm flat nozzle with scraper
- 85) Steel brush
- 86) 1 cm flat nozzle
- 87) Round nozzle for high pressure water

# 5. TECHNICAL DRAWINGS

## STEAM POWER

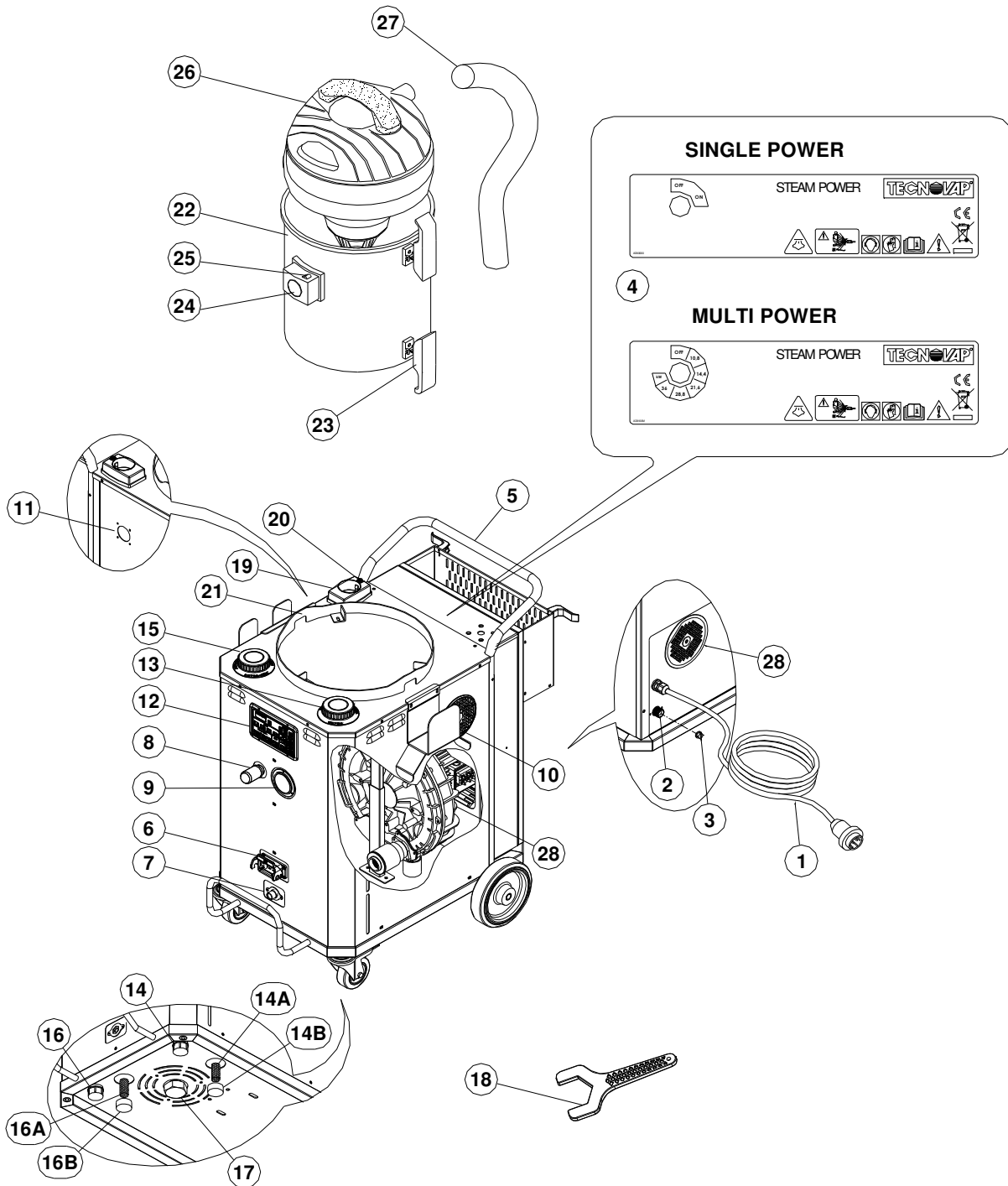

KIT RADAMES

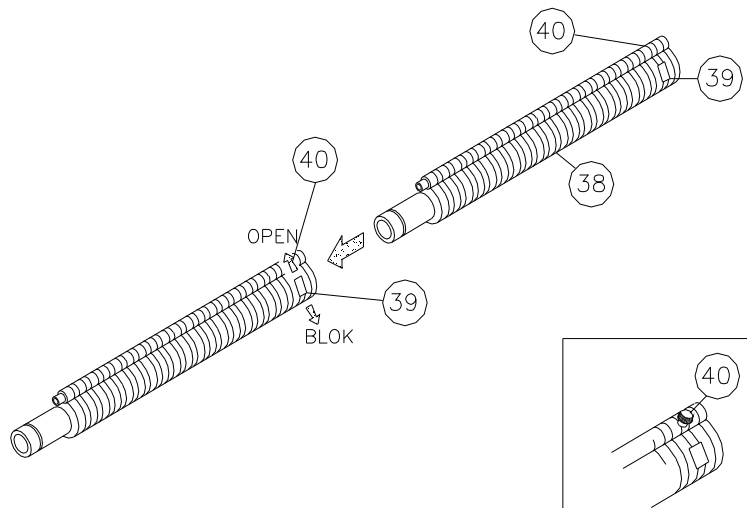
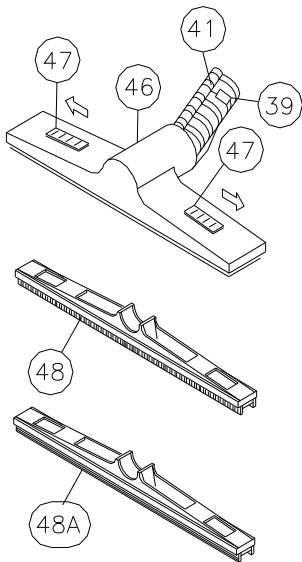
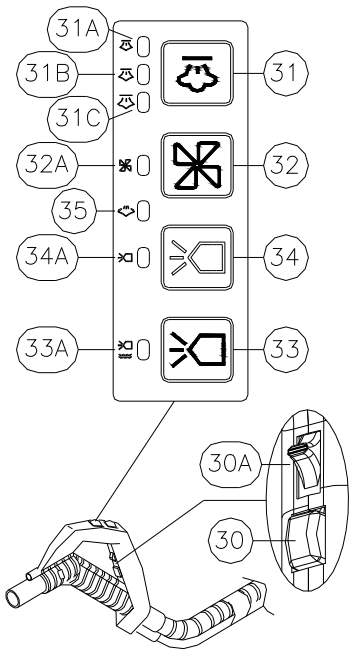
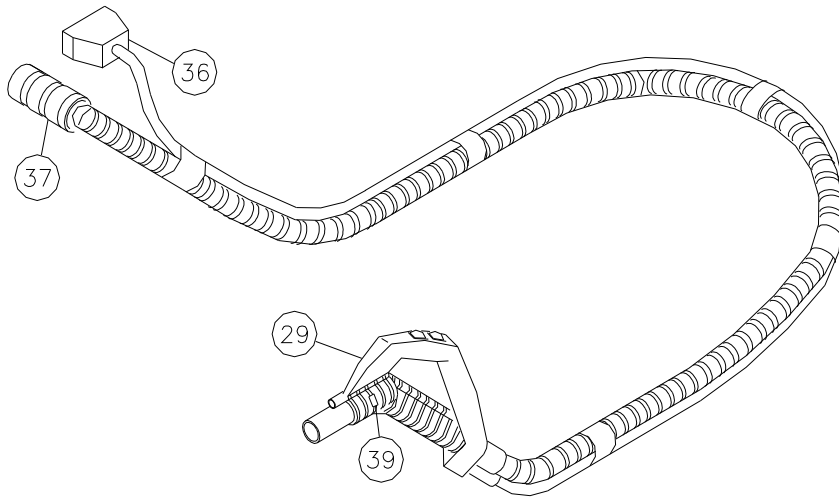

Optional

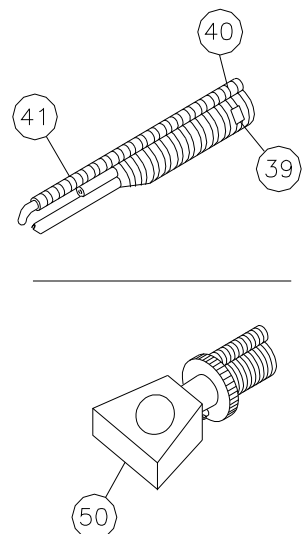
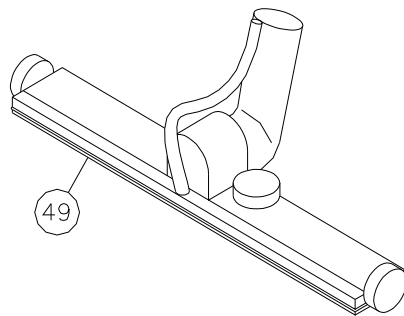
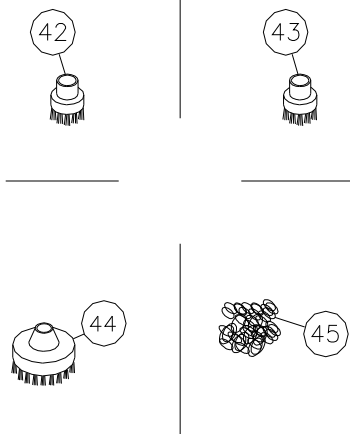

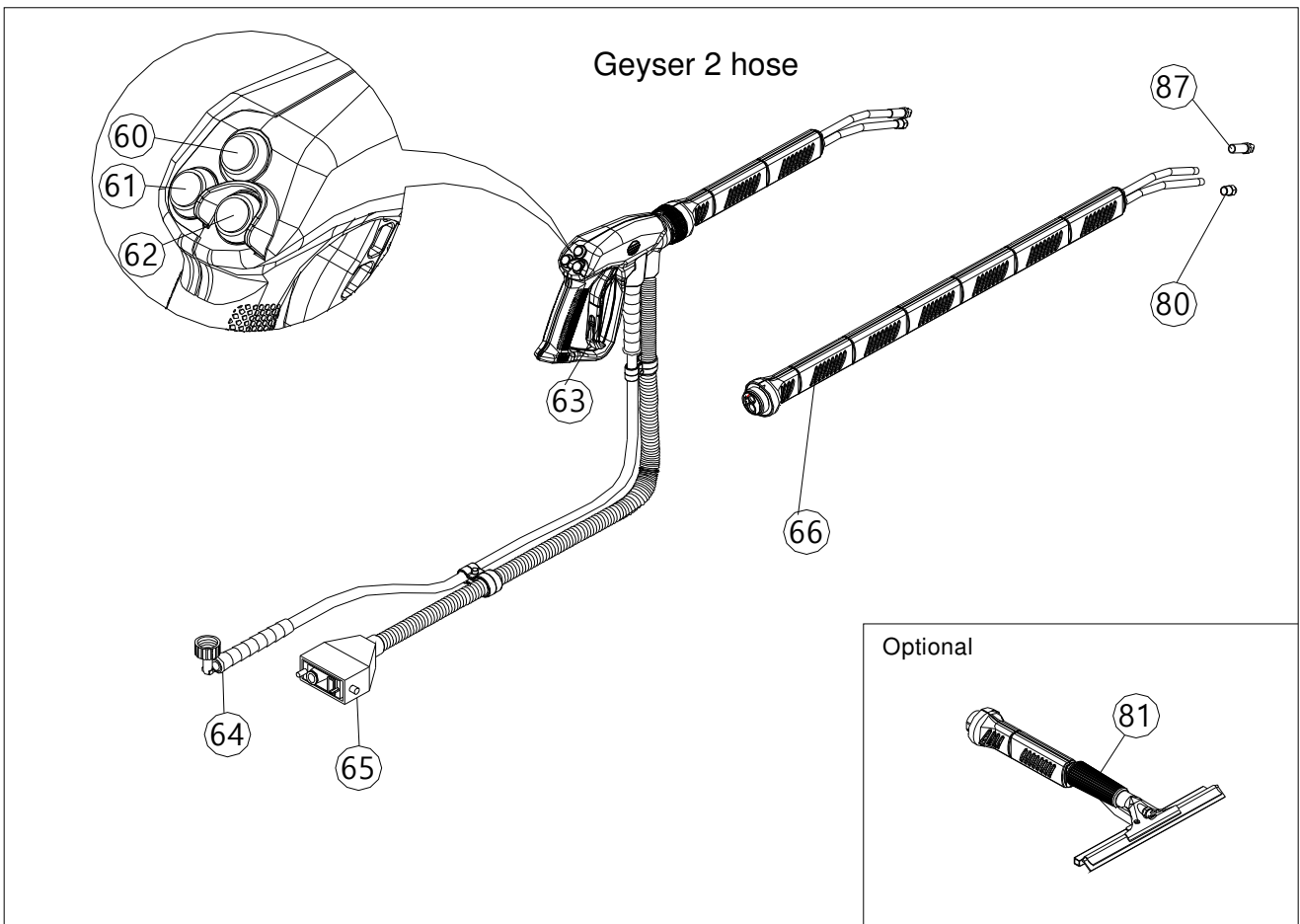
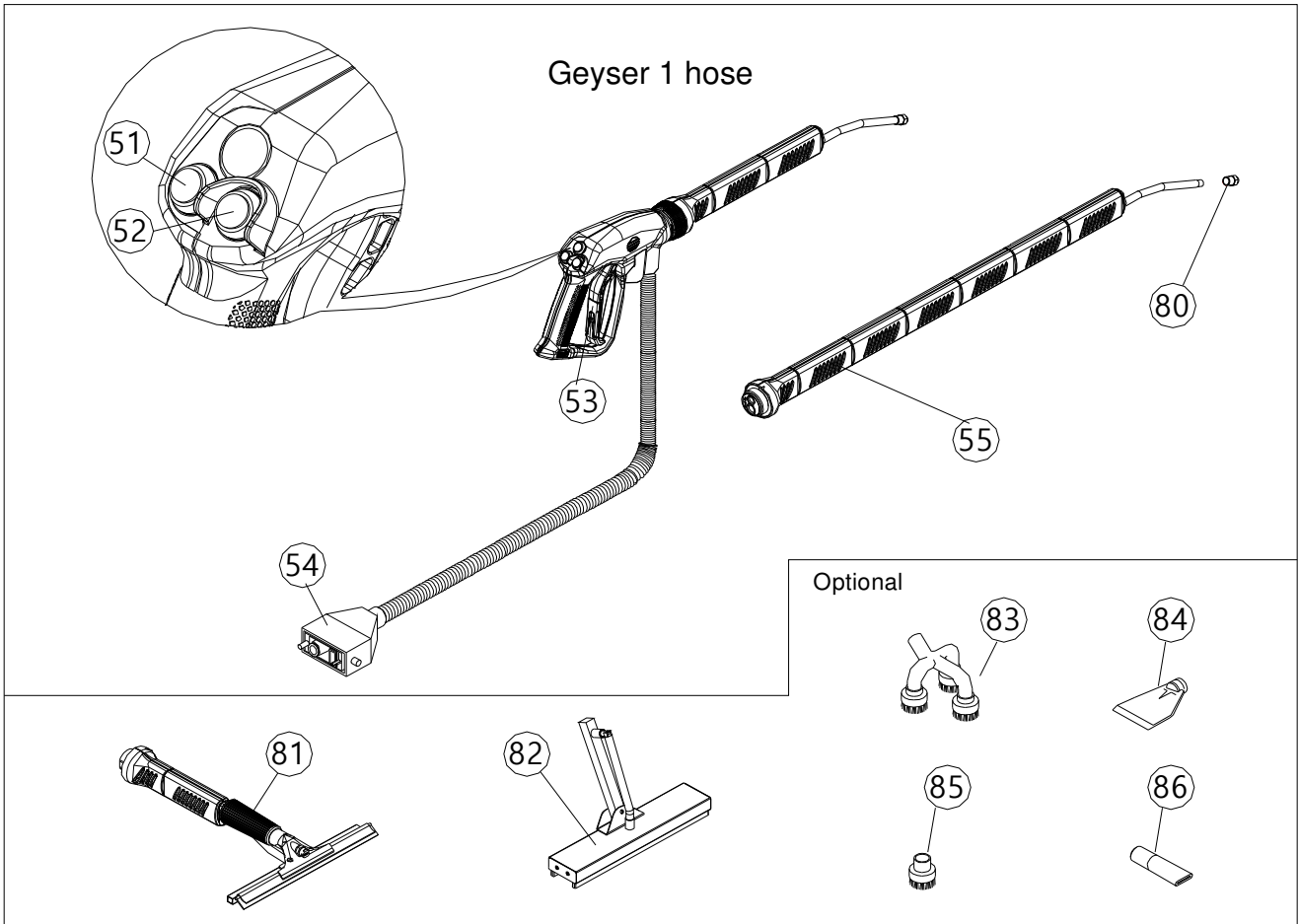

Bacchus hose

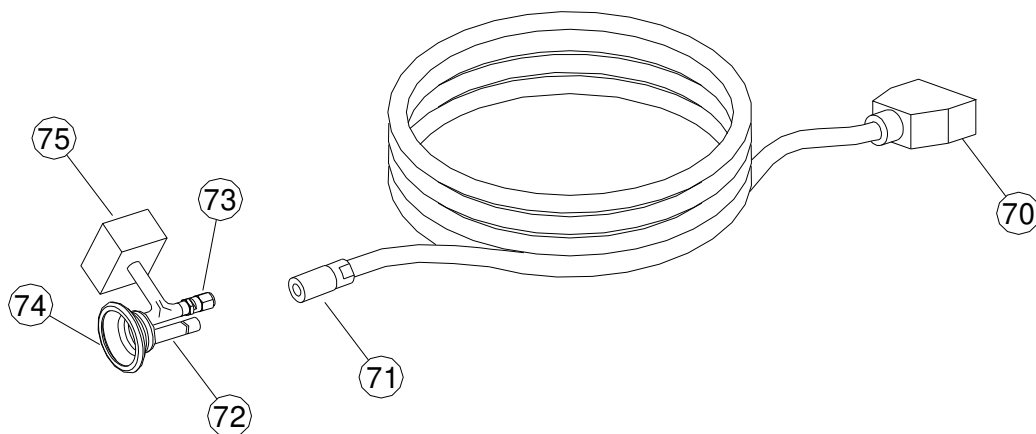

Suction hose

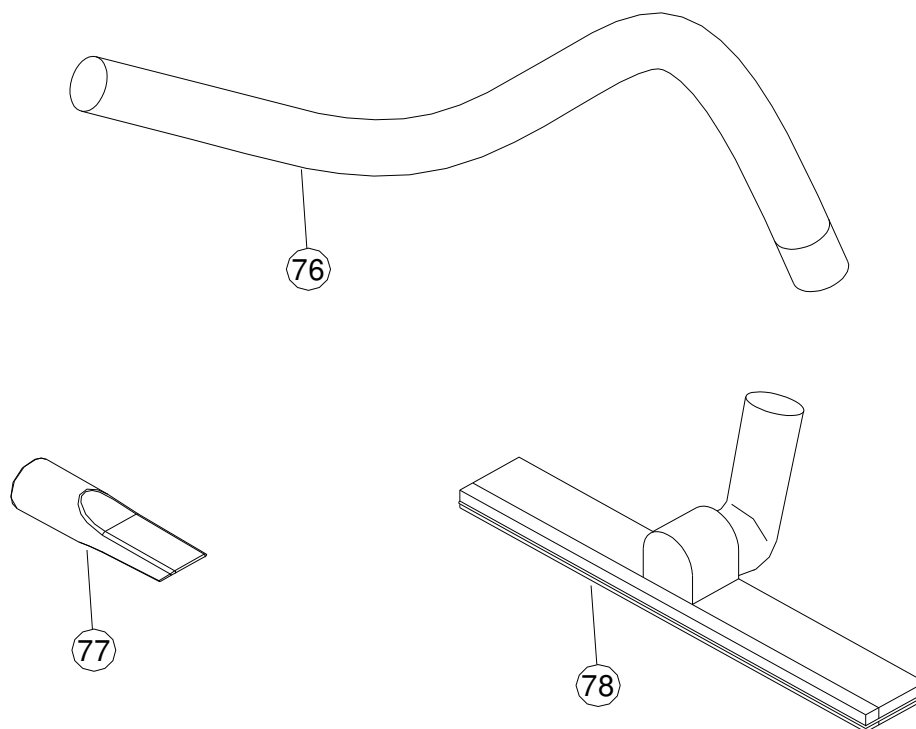



## CONTROL PANEL (POS. 12)



### Presence of tension

Informs the user that the appliance is connected to the power source.



### Steam ready indicator

If this indicator is lit up, the generator is ready to use.



### “Low water” indicator

Indicates the lack of water in the tank, the indication is accompanied by an intermittent buzzer. If lit, the overheated water injection and the high pressure pump cannot be used; steam production will be interrupted.



### “Low detergent” indicator

Indicates the lack of detergent in the tank, the indication is accompanied by a continuous buzzer. Attention! The continuous acoustic signal must have priority on the water intermittent acoustic signal. For security reasons, please check the activation of both warning lights.



### Power button

Powers the electronic components, steam solenoid valves, boiler refilling pump and high pressure pump.



### Boiler activation button

Activates the heating elements, the detergent pump and the overheated water injection valve. If there is no water inside the boiler, the LED light will blink and the heating elements will not be activated as long as the default level of liquid into the boiler will not be achieved. After achieving the correct water level, the light will be fixed.



### Direct water intake button

Activation of water supply from the water net; the LED light will show the status with a steady light.

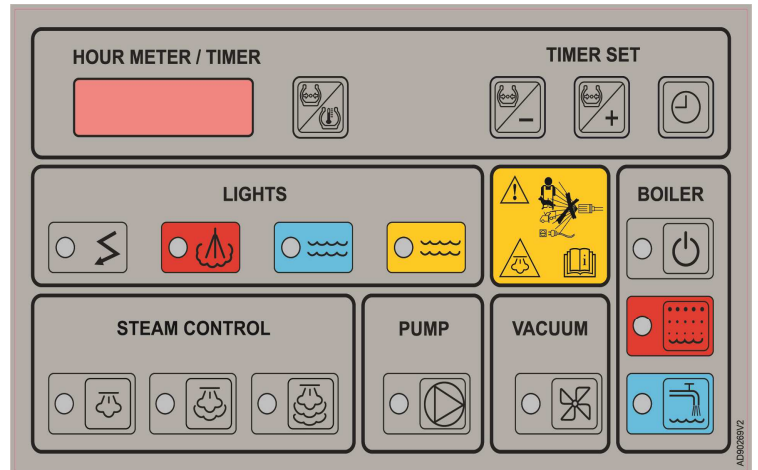

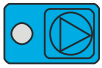

## High Pressure Pump

Activates the high pressure pump, its functioning is marked as follows:

Led light switched off = pump not activated;

Led light switched on = pump activated;

Flashing Led light = pump in stand-by mode (if the high pressure water is not used for over 40 seconds, the system will bring the pump in stand-by mode, the pump will be functioning again activating the lever positioned on the supplied lance).

Once the pump starts, the display will show for few seconds the pump working hours.



Detergent discharging switch, pressure / temperature / total and partial hour counter display.



Allows to decrease the machine's pressure up to the desired value (1 – 10 bar).



Allows to increase the machine's pressure up to the desired value (1 – 10 bar).



Clock set-up button (the current time is displayed only when the machine is in stand-by mode).



Vacuum button/warning light (active on models with vacuum cleaner).



Minimum steam button/warning light.



Medium steam button/warning light.



Maximum steam button/warning light.

## 6. OPERATING INSTRUCTIONS



- (a) After opening the packaging, secure the suction unit bin (22) onto the disc by acting on catches (23). Insert one end of the coupling hose (27) in the suction unit head (26), the other end in the female coupling (19) (only for steam generators with integrated suction unit).
- (b) Remove the tanks caps (13 and 15) and fill in water and detergent in the relevant tanks, **water inside the blue funnel and detergent into the yellow funnel. It is recommended to be very careful during this process because an inverted filling up** (detergent into the water tank or water into detergent tank) **causes a steam generator fault.**
- (c) When using detergent (not foamy for extractions machines), please follow the specific instructions: normally 1 liter of detergent for every 10 liters of water (detergent percentage about 10%), making sure to fill in first the detergent to obtain a better mixing. **Please be careful with the detergent to be used as some available in commerce will emanate highly toxic gases when heated above 100°C. Always consult the MSDS datasheet from the supplier.**

**Always take at hand the detergent safety file to allow the operator to consult it in case he gets in contact with the detergent accidentally.**

The detergent tank has to be filled only with detergent diluted with water, **not with water only,** unless you are not using demineralized water.



The usage of water only (not demineralized) instead of detergent causes faults to the mixing circuit.

- (d) Insert the plug (1) into the electrical outlet, making sure that the voltage and the amperage correspond with the data printed on the technical label on the machine.
- (e) Switch on the appliance by turning the main switch (4) to ON or to the desired power (only multipower models).



Activate the stand-by  and the boiler  switches.

- (f) The machine is equipped with a protective system against thermal shock. Therefore, when cleaning the boiler or in case of water lacking inside the boiler, the system automatically disconnects the heating elements supply. This process is recognizable thanks to the blinking LED light on the boiler switch . The system can intervene also after the boiler refilling; in this case it will last for 30 seconds and it does not have to be considered as a faulty signal.





## Hour counters

The appliance is equipped with two hour-counters: total (not resettable) and partial (resettable by the user). To visualize the hour counters, switch the appliance ON with the power button . Act on the button  to visualize in progression the current pressure in the boiler, the temperature, the total hour counter, "C1" indication will appear on the display followed by the total hour counter. Press again the button  in order to visualize the partial hour counter; "C2" indication will appear on the display followed by the partial hour counter.

## Reset of the partial hour counter

Switch the device off by using the main switch (4). Press both switches   and hold them, switch the device on by putting the main switch in ON position, once finished the LED lights sequence, release the switches and the hour counter C2 will be brought to 0000.

## Clock set-up



Switch the device off by using the stand-by switch  (the main switch has to remain in ON position). The display will visualize the current time, to adjust it hold the switch  and then operate with the -/+ switches   to decrease or increase the time displayed.

Note: the timer is equipped with a battery for time memorization, if the device remains without power supply for a period of more than 30 days, the timer will be reset and it will have to be set again.

## Indication of boiler cleaning operation (C A L C )

The controller has been programmed to warn the user about the ordinary maintenance period; the system has been programmed in order to warn each 20 effective working hours (steam solenoid valve on). Proceed as described in the section 8.1 "boiler maintenance" in order to perform the liquids drainage.

## Warning indication (C A L C ) restoration

After having performed the maintenance, press and hold the switch  and switch the device off by using the switch . The warning C A L C will be restored.

### Connection to the water net

Connect a tube with a 3/4" female valve to the water inlet (2), the maximum applicable pressure is 6bar. Make sure that the same tube is suitable for the pressure of the water plant and for the connection to the drinkable water net.

To use this function it is necessary to enable the "water supply network"  switch.

Attention!!

In case of water lacking or dirt inside the filter, this function is automatically deactivated; to restore it, it is sufficient to switch the steam generator off and on after having removed the eventual obstruction from the tube or after having cleaned the filter (refer to the procedure described in the chapter 8.3).

### "Low water" indicator

The water lacking inside the tank is signaled by the light .



In case of water lacking the control system deactivates the high pressure pump, the solenoid valve for hot water injection and the heating elements; when this light is on, it is not possible to use steam, nor hot water injection, nor high pressure water.

### "Low detergent" indicator

The detergent lacking inside the tank is signaled by the light .

In case of detergent lacking the control system deactivates the detergent pump.



It is sometimes possible that air enters into the detergent circuit; in case the detergent does not come out regularly after the refilling, proceed as follows:

- 1) Make sure there is detergent in the tank (15)
- 2) Switch the generator on by activating only the switch . The switch  has to remain off.
- 3) Activate the steam button (31 on Radames), hold the detergent button (34 on Radames, 51 on Geyser 1 or 60 on Geyser 2) and press the safety steam release button (30 on Radames, 53 on Geyser 1 or 63 on Geyser 2) located on the handgrip, press then the button  on the control panel to activate the detergent pump, hold this button until detergent comes out from the tool.
- 4) The detergent has been triggered and the machine is ready for use.

## 7.1. OPERATING WITH RADAMES KIT

### Warning!!

**Switch off the steam generator before connecting the steam hose.**

Insert the male suction hose (37) in the female hose coupling (19) located on the suction unit and the steam plug (36) in the steam socket (6) located on the machine. Push until the catches have locked into their seats and turn the closing lever. Switch on the main switch (4) and   buttons for steam production then wait until the  light comes on, indicating that there is steam in the boiler. The steam ready indicator on the hand grip (35) also lights up.

Select the required quantity of steam delivery using the button (31) on the grip (whenever the machine is switched on the steam selector is always disabled, the LEDs on the steam grip flash alternately to indicate that the required delivery level must be selected); one of the LEDs (31A, 31B or 31C) comes on steady to indicate the set value. (1=minimum 2=medium 3=maximum), press the button (30) to deliver the steam.

Use the lever (30A) to lock the steam delivery button (30).

Button (32) activates the suction unit which can be activated even during steam delivery.

Button (34) allows you to add detergent to the steam and must be run at intervals of a few seconds to avoid excessive detergent injection. For models with overheated water injection, adhere to the operating mode described above, activating button (33).

Both the detergent and the overheated water function must be run at intervals (e.g. 20 seconds on 20 seconds off), neither function is intended for continuous run.

The detergent and/or overheated water are delivered only if the steam outlet is active and the “steam presence” LED  is on.

### Warning!!

**The button (33) releases from the lance the overheated water under pressure at a temperature which, depending on the model, can reach 180°C. Be very careful not to press this accidentally and make sure that the jet never points at persons or animals.**

For steam cleaning combined with injection of detergent and/or overheated water and suction, select and install the most suitable accessory after having first switched off the machine:

Inserts holder brush (46): with relative inserts (48 or 48A). The inserts are fitted by moving the locking levers (47) inwards (OPEN position), pushing the inserts upwards and then moving the locking levers outwards (BLOCK position). Afterwards fit the brush to the hand grip or to extension tube/s (38) (one or both) and secure everything in place using the locking lever (39). Finally, tighten the fastening knob (40). Remember that the indicators on the hand grip (32A - 33A - 34A) must be switched off or flashing (31A - 31B - 31C) until the operation has been completed.

Steam/suction turbo lance (41): to be used by itself or with brushes (42 or 43), depending on the cleaning operation to be performed.

To use this accessory, follow the brush assembly instructions provided above.

Once cleaning has been completed, it is advisable to suck up around 3-5 litres of clean water to clean out the inside of the hose (29) and the suction conduits. Clean and dry all the accessories used. Lift the suction unit bin (22), empty and rinse and then leave to dry before repositioning.

## 7.2. OPERATING WITH GEYSER 1 KIT

### Attention!!

**It is recommended to switch the steam generator off before connecting the steam hose to the steam outlet (3).**

Insert the steam plug (54) into the steam outlet (6) on the machine and activate the locking lever.

Insert the desired lance (55) directly onto the handgrip making sure to lock everything with the fixing nut; screw onto the lance either the nozzle (80) or various optional accessories (82 / 83 / 84 / 85 / 86); or insert onto the handgrip the window cleaner (81), depending on the cleaning to be carried out. Now your lance is ready for use.

Activate the main switch (4) and the buttons  and  for the steam production and wait approximately 5 minutes until the indicator  lights up indicating the presence of steam inside the boiler.

The lever (53) and the buttons (51, 52) located on the hose have to be in OFF position.

Use the lever (53) on the handgrip to activate steam flow, the button (51) to spray detergent or the button (52) to spray hot water together with steam.

The supply of detergent and overheated water is only possible if steam is in use and if the LED light “presence of steam”  is on.

### Attention!!

**Using the switch (52) you will get hot water under pressure which, according to the model of the machine, can reach a temperature of 180°C; please pay attention that the switch is not pressed accidentally and do not direct the jet against persons or animals.**

### 7.3. OPERATING WITH GEYSER 2 KIT



#### Attention!!



**It is recommended to switch the steam generator off before connecting the steam hose to the steam outlet (3).**

Insert the steam plug (65) into the steam outlet (6) located on the steam generator and activate the locking lever.

Screw on the connection (64) of the high pressure pump hose onto the inlet for the high pressure hose (7).

Insert the desired lance (66) directly onto the handgrip making sure to lock everything with the fixing nut; screw onto the lance the nozzles (80 e 87) or insert onto the handgrip the window cleaner (81) depending on the cleaning to be carried out. Now your lance is ready for use.

Activate the main switch (4) and the buttons  and  for the steam production.

Wait until the indicator  lights up indicating the presence of steam inside the boiler. Then activate the switch  to start the high pressure pump.

Attention!! This model is equipped with a “pump stand-by” system for energy saving, therefore in case the high pressure activation lever (63) is not activated for a period of 40 seconds the system activates the stand- by of the pump. This status is signalized by the blinking light “high pressure pump”; it is sufficient to activate the lever (63) to restart the system. Activate the switch (60) to spray detergent or the switch (61) to spray overheated water while steam is in use (switch 62 activated).

The supply of detergent and overheated water is only possible if steam is in use and if the LED light “presence of steam”  is on.

Adjust if necessary the desired pressure of the High Pressure group through the regulator (8).

#### Attention!!

**Using the switch (61) you will get hot water under pressure which, according to the model of the machine, can reach a temperature of 180°C; please pay attention that the switch is not pressed accidentally and do not direct the jet against persons or animals.**

### 7.4. OPERATING WITH SUCTION HOSE (OPTIONAL)

Insert one end of the vacuum hose (76) into the inlet (24) on the vacuum cleaner and put the lance (77) or the brush (78) on the other end depending on the cleaning to be carried out.

The vacuum hose can be used independently from operation of Geyser 1 and Geyser 2 hoses, press the button  located on the control panel (12) to switch on the vacuum cleaner.





## 7.5. OPERATING BACCHUS MODE (OPTIONAL)

The appliance is provided of “Bacchus” function, sanitation function suitable for the treatment of different kinds of plants (i.e. wine-making, pharmaceutical, etc.).

Such function provides the reduction of pressure in the boiler, the possibility to program the appliance’s switch on/off (stand-by) and the safety system against excessive pressure in the treated plant.

Insert the steam plug (70) into the steam outlet (6) of the steam generator and activate the locking lever.

Connect the Garolla valve (74) to the plant, then insert the female rapid connection (71) of the Bacchus hose into the male connection (72) on the Garolla valve; always use proper protection systems against burning.

Activate the main switch (4) and the buttons   or the steam production.





The steam generator automatically recognizes the inserted Bacchus hose and activates the corresponding steam selection buttons on the control panel; besides, the operating pressure will be automatically set at 6 bar.

Wait until the indicator  lights up indicating the presence of steam inside the boiler.

Regulate the desired quantity of steam by using the respective switches  minimum steam



 medium steam  maximum steam.



### Self-start programming

Press the button  in order to switch the steam generator off. Press the button  and keep it pressed until the display starts blinking (approx 7 seconds); use the buttons   in order to set the desired start time (keeping the buttons long pressed, the time will be increased or decreased quickly).

The set time is memorized and, if the self-start programming is enabled, the system will activate the machine every day as scheduled.

### Self-start enabling

Press in sequence the buttons   releasing the first button only after having pressed the second one. The button  will start blinking and the display parametric segments will alternatively lit to indicate that the function has been enabled. (Repeat the operation in sequence for the deactivation).

Use the respective buttons    in order to select the quantity of steam desired to be produced at the start (the selected flow will be pointed out by a respective indicator light on the button).

The system will activate the steam generator at the previously set time for 2 hours, afterwards it will be switched off. Just press any key within the above indicated period of time in order to deactivate the automatic switching off system.

## 7. MAINTENANCE

### 8.1. Maintenance of the boiler (mud drain)

#### ATTENTION

**DISCONNECT THE UNIT FROM THE ELECTRICAL POWER SUPPLY BEFORE CARRYING OUT USER MAINTENANCE.**

#### ATTENTION. BURNING DANGER

**The boiler cleaning must be carried out when the equipment has cooled down (i.e. switched off for at least 5 hours) – for this reason we suggest to maintain the boiler in occasion of the following use, as long as at least 5 hours have passed. Please proceed as follows:**



The device is equipped with a maintenance advise system, which every 20 effective working hours displays the advice “CALC” to warn the user to proceed with the boiler cleaning.

When this advice appears on the display it is still possible to use the unit until the end of the cleaning process; then, it will be necessary to switch the unit off by turning the main switch (11) and unplugging the power cable (8).

Place a recipient under the machine, remove the boiler drain cap (6) and wait until the boiler is completely emptied.

Clean eventual residuals from the cap with running water, check the efficiency of the gasket located on the bottom of the cap and, if necessary, substitute it (please contact your supplier for the spare parts). Close the drain cap again.

Using water with hardness higher than 10 french degrees, (according to the usage of the unit, > 2 hours / day) it is necessary to use water treated with a proper water softener system, which can reduce the calcium carbonate up to less than 4 french degrees, increasing by consequence the liability of the steam generator. (for any further details or to buy a water softener system, contact your supplier).

The cleaning of the boiler is completed, insert the power cable (1) into a suitable plug and activate the main switch (4) and the switches   is recommended to activate also the lever (53) on the Geyser 1 tool or the switch (62) on the handgrip of the Geyser 2 tool to allow the outlet of the air remained in the empty boiler. Wait until the refilling system has finished (approx. 3 minutes).

After completing boiler maintenance, proceed by following the instructions described in paragraph (f) of chapter 7.

## 8.2. Maintenance of the High Pressure group

The maintenance has to be carried out by specialized and authorized personnel.

Substitute the pump oil, valve groups and pumping seals according to the instructions indicated below.

After the first 50 hours	Every 500 hours	Every 1000 hours (average period which has to be reduced in case of heavy duty)
Oil change	Oil change	Checking / replacement: valve groups, pumping seals

Activating the pump with the switch  for a few seconds the display will show an hour meter which indicates the effective working hours of the pump.

When reaching the first 50 working hours, while turning the pump on the display will show the advice "PUMP" which indicates the need to proceed with the first oil change; afterwards this advice will appear every 500 working hours, as indicated above.

Refer to the same table for the substitution of valve groups etc. according to the "pump" working hours shown on the display.

### Oil changing

- Put a recipient underneath the cap (B)
- Unscrew the oil drain cap (B)
- Unscrew the cap with dipstick (A)
- Let oil flow out into the recipient previously placed.
- Reposition the cap (B)
- Insert oil from the cap (A) according to the table below.
- Cling on the dipstick and on the reference (C) on the hole to visualize the correct oil level.

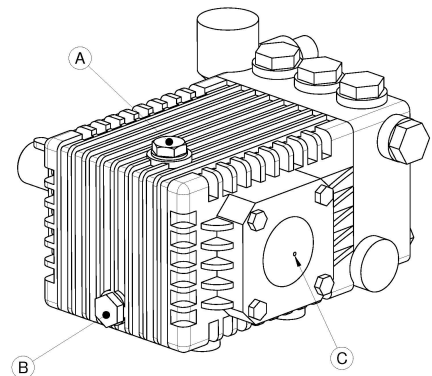

### Recommended oils

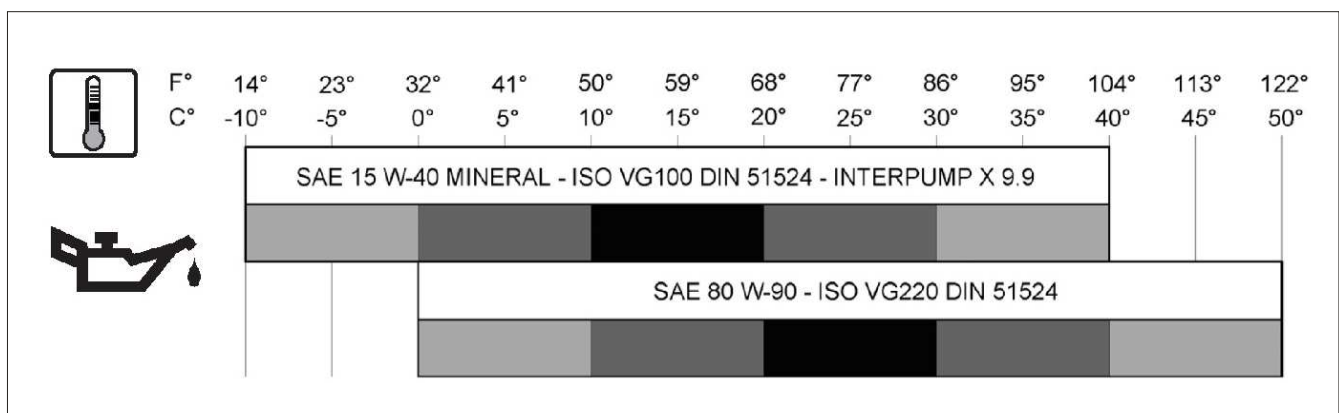

### Maintenance indication (PUMP) restoration

After having changed the oil etc. press and hold the switch  for 10 seconds.







### 8.3. Maintenance of the filters

Periodically check the filters (14A) (16A), unscrew the cap and rinse the metallic filter on it; substitute it if necessary.

Replace the cap with the filter correctly, otherwise the High Pressure group will not work regularly. Attention, after having substituted the filter it is necessary to purge the High Pressure group; turn the regulation knob (8) counterclockwise almost completely, then activate the trigger gun for a few seconds at low pressure, then position again the regulation knob on the desired pressure.

Remove the filter inside the water connection valve (3) by grasping with a pliers the proper tang located in the center of the filter; clean it and reposition it.

## 9. BEFORE REFERRING TO THE TECHNICAL SERVICE

INCONVENIENCE	POSSIBLE CAUSE	REMEDY
Machine does not produce steam and High Pressure module does not work.	Lack of power. Protection system activated.	Make sure plug (1) is well inserted, check if the main switch (4) is in ON position and if the switches   are activated.
The red "low water" indicator lights up. 	All the water from the water tank (13) has been consumed.	Refill the water tank (13) with clean water.
There is no injection of detergent.	All the detergent from the detergent tank (15) has been consumed. The "ready steam" light  is off.	Refill the detergent tank (15) and proceed with the reactivation of the pump (ref. paragraph "refilling of detergent"). Wait until the "ready steam" light lights up.
Lack of High Pressure function .	Lack of power supply to the High Pressure pump.	Make sure the switch  is activated and the plug (8B) is well inserted into the socket (8A).
When switched on, the pump does not make any noise.	<ul style="list-style-type: none"> <li>▪ The pump is not primed and is operating dry.</li> <li>▪ There is no water supply.</li> <li>▪ The delivery line is closed and does not let the air flow out of the pump.</li> </ul>	<ul style="list-style-type: none"> <li>▪ Add water into the tank (13) until the filling up.</li> <li>▪ Check the valve (2) and the tap of the water net.</li> <li>▪ Turn the knob (8) counterclockwise acting on the high pressure lance.</li> </ul>
The pump does not give the rated flow and makes excessive noise.	<ul style="list-style-type: none"> <li>▪ Cavitation due to: feed pipes and / or filter, insufficient flow, high water temperature, clogged filter.</li> </ul>	<ul style="list-style-type: none"> <li>▪ Inlet water does not have to go over 25°C, add cold water into the tank.</li> </ul>
The pressure supplied from the pump is not sufficient.	<ul style="list-style-type: none"> <li>▪ The appliance (nozzle) is too large or is worn out.</li> </ul>	<ul style="list-style-type: none"> <li>▪ Substitute the nozzle on the lance with the suitable model (check flow/pressure on the technical label of the high pressure group).</li> </ul>
The pump overheats.	<ul style="list-style-type: none"> <li>▪ The oil in the sump of the pump is not at the proper level or it is not of the recommended type.</li> </ul>	<ul style="list-style-type: none"> <li>▪ Add or change the oil.</li> </ul>
Steam does not come out.	<p>A) The boiler has not reached yet the operative pressure (green light  is off).</p> <p>B) The lever (53) or the switch (62) have not been activated.</p>	<p>A) Wait some minutes.</p> <p>B) Activate the lever (53) (Geyser 1) or the steam button (62) (Geyser2).</p>
Water or steam leak through the connections of the accessories.	Check the wear of the o-rings.	Clean and lubricate the o-rings. If necessary, substitute them with the spares supplied.

Visualization of "ALL1" on the display.	Water filters obstructed, wrong power supply to the device, drain cap not inserted.	Clean the filter of the water tank, check that the voltage corresponds to the data indicated on the technical label. Insert the drain cap.
Visualization of "ALL2" on the display.	Temperature exceeded the threshold, drain cap not inserted, boiler under pressure after the mud draining.	Insert the drain cap, discharge the air inside the boiler by activating the steam switch on the handgrip.
Blinking light 	Protection water net control activated.	Control the presence of pressure and water into the valve (2). Remove and clean the filter of the water net valve (3).
Drops of water come out of the accessories.	At beginning of work water condenses in the tubes and accessories due to the difference in temperature.	After a few minutes of use this problem will cease. If it continues, proceed to the cleaning of the boiler.
Noise inside the generator.	The boiler getting cold, after about 6-7 hours creates an internal depression which, at each ignition, provokes some vibrations.	Wait the pressure stabilization (about 2-3 minutes), the noise will disappear.
Accessories do not fit perfectly.	There is dirt build up in the joints and locking latches.	Clean and lubricate the joints.

## 10. DECLARATION OF CONFORMITY



**DICHIARAZIONE DI CONFORMITA'**  
 (EC DECLARATION OF CONFORMITY)



**TECNOVAP S.R.L. Via dei Sassi, 1A 37026 Pescantina Verona Italy**

con la presente dichiara che:

la macchina per pulizia a vapore modello:

(Certifies that the steam cleaning machine model:)

**Steam Power**

**Risulta conforme alle specifiche delle direttive**

(conforms to the specifications of directives)

**2014/35/UE 2014/30/UE 2011/65/UE 2014/68/UE**

Per il controllo della conformità alle sopraindicate direttive, sono stati seguiti i seguenti standard:

(For the checking of conformity to the above directives, the following standards have been used):

Riferimento alle norme armonizzate:

(Reference to harmonized standards):

**EN 60335-1**

**EN 60335-2-69**

**EN 60335-2-79**

**EN 55014-1**

**EN 55014-2**

**EN 61000-3-2**

**EN 61000-3-3**

*PESCANTINA – VERONA (ITALY) 07-01-2020*

  
**Franchini Giuseppe**  
 (Managing Director)















THE MANUFACTURER RESERVES THE RIGHT OF TECHNICAL AND STRUCTURAL MODIFICATIONS  
AS WELL AS IMPROVEMENTS WITHOUT PRIOR NOTICE.

Tecnovap S.r.l. – Via dei Sassi 1/a 37026 Pescantina, Verona – Italy +390456767252 – info@tecnovap.com – www.tecnovap.it